

Affirmative Action
(231)724-6703
FAX (231)722-1214

Assessor/
Equalization Co.
(231)724-6386
FAX (231)724-1129

Cemetery/Forestry
(231)724-6783
FAX (231)724-4188

City Manager
(231)724-6724
FAX (231)722-1214

Clerk
(231)724-6705
FAX (231)724-4178

Comm. & Neigh.
Services
(231)724-6717
FAX (231)726-2501

Computer Info.
Technology
(231)724-4126
FAX (231)722-4301

Engineering
(231)724-6707
FAX (231)727-6904

Finance
(231)724-6713
FAX (231)726-2325

Fire Department
(231)724-6795
FAX (231)724-6985

Human Resources
Co. (Civil Service)
(231)724-6442
FAX (231)724-6840

Income Tax
(231)724-6770
FAX (231)724-6768

Mayor's Office
(231)724-6701
FAX (231)722-1214

Planning/Zoning
(231)724-6702
FAX (231)724-6790

Police Department
(231)724-6750
FAX (231)722-5140

Public Works
(231)724-4100
FAX (231)722-4188

SafeBuilt
(Inspections)
(231)724-6715
FAX (231)728-4371

Treasurer
(231)724-6720
FAX (231)724-6768

Water Billing
(231)724-6718
FAX (231)724-6768

Water Filtration
(231)724-4106
FAX (231)755-5290

MUSKEGON



West Michigan's Shoreline City
www.shorelinecity.com

City of Muskegon, Water Filtration Plant

REQUEST FOR PROPOSAL: Harvey Booster Station Pump #2 Rebuild

Background:

The City of Muskegon Water Filtration Plant is seeking competitive bids for the rebuilding of the Harvey #2 high service pump.

Facility Information:

Harvey Booster Station is located at 2501 South Harvey Street, Muskegon, MI 49442 and the capacity of pump #2 is 6 MGD.

Pump Repair Scope:

- Pick up existing pump parts at the City of Muskegon Water Filtration Plant located at 1900 Beach Street, transport to repair facility, return and install at the Harvey Street Booster Station. Include loading and unloading of pump and assembly onsite due to clearance of the building.
- All painted surfaces will have to be prepared for painting.
- Pump head and top column pipe: Paint inside and outside with two (2) coats of NSF-approved epoxy paint.
- Stuffing box: Provide new stuffing box bushing for 1 ¹⁵/₁₆" line shaft, packing, stainless studs, and nuts.
- Column pipe: Paint inside and outside with two (2) coats of NSF-approved epoxy paint and provide new stainless-steel bolts and nuts.
- Pump bowls and suction bell (use city supplied OEM suction bell, suction bell bearing bushing, 3 bowls, 3 bowl bearing bushings, and 3 stationary rings): Paint outside with two (2) coats of NSF-approved epoxy paint.
- Line shaft: Provide new stainless-steel top line shafts and two new stainless-steel intermediate line shafts. Provide new stainless-steel line shaft threaded couplings.
- Rubber line shaft bearings: Provide two new rubber line shaft bearings to fit existing drop in bearing retainers.
- Impellers: Check balance and balance if necessary.
- All internal and external submerged surfaces of pump must be clear of any debris and oils and disinfected with 200 ppm chlorine prior to installation.
- Motor: Set motor, attach to power supply, check alignment, startup, and check vibration. Balance motor if required.
- Pump Testing: A minimum of either one week or 20 hours of pump operation.
- Submit as found as left report to Muskegon Water Filtration Plant.

City of Muskegon, 933 Terrace Street, P.O. Box 536, Muskegon, MI 49443-0536

<http://www.shorelinecity.com>

MUSKEGON



West Michigan's Shoreline City
www.shorelinecity.com

Proposal submittals:

The City will receive sealed bids until 2:00 PM local time on Tuesday, September 15, 2020. Send, or deliver, sealed proposals labeled "Harvey Booster Station Pump #2 Rebuild" to:

City of Muskegon: City Hall
City Clerk's Office
933 Terrace St
Muskegon, MI 49440

Pre-Bid Meeting:

Mandatory pre-bid meeting will be held on Wednesday, September 9, 2020 at 10:00 AM at the City of Muskegon Water Filtration Plant. Questions and answers will be compiled during the pre-bid meeting and shared with all parties. This information will become addenda to the proposal.

Contacts:

City of Muskegon WFP
Joe Buthker, Chief Operator
1900 Beach St
Muskegon, MI 49441
(231) 724-4105
joe.buthker@shorelinecity.com

City of Muskegon WFP
Josh Parmer, Maintenance Technician
1900 Beach St
Muskegon, MI 49441
(231) 724-4584
joshua.parmer@shorelinecity.com

MUSKEGON

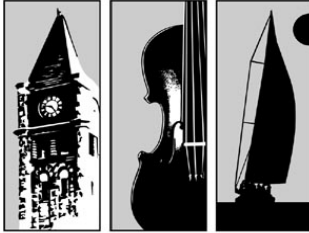

West Michigan's Shoreline City
www.shorelinecity.com

SULZER

CROSS SECTION DRAWINGS - TYPE: SJT
Bowl Assembly
(Multistage Colletted Impeller Construction)

Series	11.71	Page
CROSS SECTIONS		US
Apr - 10		C08

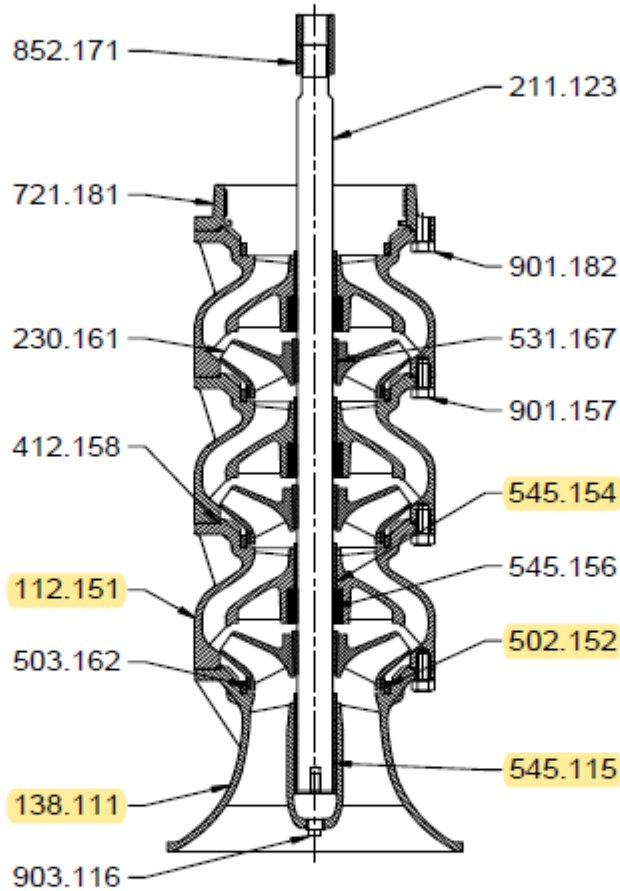

Find No.	Description
138.111	Suction Bell
545.115	Bearing Bushing (Suction Bell)
903.116	Threaded Plug (Suction Bell)
211.123	Pump Shaft
112.151	Bowl
502.152	Stationary Ring

Find No.	Description
545.154	Bearing Bushing (Bowl)
545.156	Bearing Bushing (Bowl)
901.157	Capscrew, Hex Head (Bowl)
412.158	O-ring
230.161	Impeller
503.162	Impeller Ring

Find No.	Description
531.167	Clamping Sleeve
852.171	Threaded Coupling
721.181	Adapter (Bowl/Column)
901.182	Capscrew, Hex Head (Adapter)

MUSKEGON



West Michigan's Shoreline City
www.shorelinecity.com

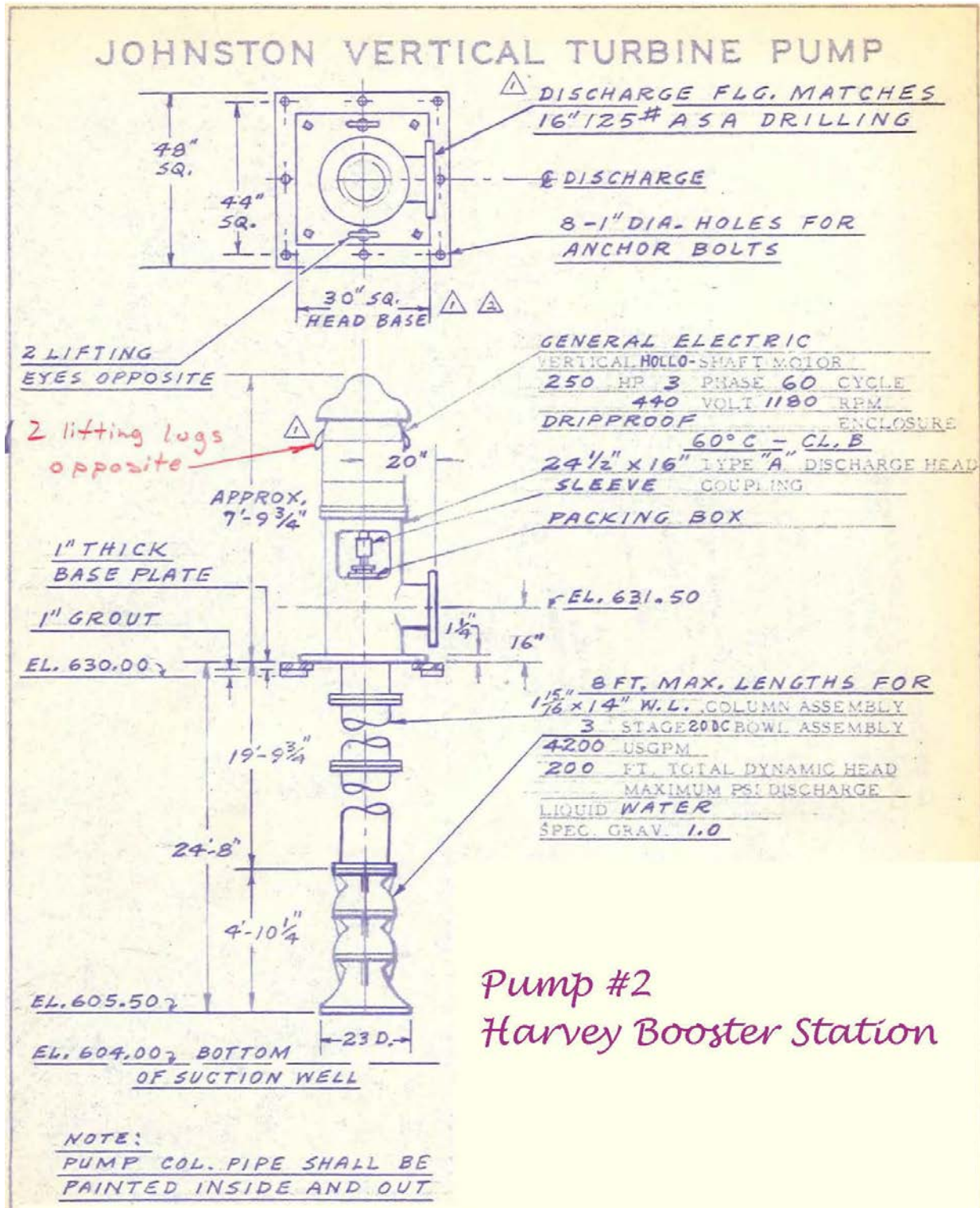

MUSKEGON



West Michigan's Shoreline City
www.shorelinecity.com

Required Insurance provided by bidder:

The BIDDER shall furnish a certificate of insurance to the City with the following coverage:

1. Hold Harmless Agreements: To the fullest extent permitted by law, BIDDER agrees to defend, pay in behalf of, indemnify, and hold harmless the CITY, its elected and appointed officials, employees, volunteers and others working on behalf of the CITY against any and all claims, demands, suits, or loss, including any costs connected therewith, and for any damages which may be asserted, claimed or recovered against or from the CITY, its elected and appointed officials, employees, volunteers, or others working on behalf of the CITY, by reason of personal injury, including bodily injury and death, property damage, including loss of use thereof, and/or the effects of or release of toxic and/or hazardous material which arises out of or is in any way connected or associated with this contract. The obligation to defend and hold harmless extends to BIDDER'S employees, agents, subcontractors, assigns and successors.
2. Insurance Requirements: The BIDDER shall not commence work under this contract until obtaining the insurance required under this paragraph. All coverage shall be with insurance companies licensed and admitted to do business in the State of Michigan and Best Rated. All coverage shall be with insurance carriers acceptable to the CITY.
3. Workers' Compensation Insurance: The BIDDER shall procure and maintain during the life of this contract, Workers' Compensation Insurance, including Employer's Liability coverage, in accordance with all applicable Statutes of the State of Michigan.
4. General Liability Insurance: The BIDDER shall procure and maintain during the life of this contract, commercial General Liability Insurance on an "Occurrence Basis" with limits of liability not less than \$500,000 per occurrence and/or aggregate combined single limit, Personal Injury, Bodily Injury and Property Damage. Coverage shall include the following extensions:
 - a. Contractual Liability;
 - b. Products and Completed Operations;
 - c. Independent Contractor's Coverage;
 - d. Broad Form General Liability Extensions or equivalent.
5. Motor Vehicle Liability: The BIDDER shall procure and maintain during the life of this contract Motor Vehicle Liability Insurance, including Michigan no-fault coverage, with limits of liability of not less than \$500,000 per occurrence or combined single limit Bodily Injury and Property Damage. Coverage shall include all owned vehicles, all non-owned vehicles and all hired vehicles.
6. Professional Liability Insurance: The BIDDER shall procure and maintain during the life of this contract and during the performance of all services Professional Liability Insurance covering all performances from the beginning of the bidder's services on a "claims made basis" and shall

MUSKEGON



West Michigan's Shoreline City
www.shorelinecity.com

maintain coverage from commencement of this contract until six (6) months following completion of the bidder's work with limits of liability not less than \$500,000 per claim.

7. **Additional Insured:** Commercial General Liability and Motor Vehicle Liability Insurance, as described above, shall include an endorsement stating the following shall be "Additional Insured": The CITY OF MUSKEGON, all elected and appointed officials, all employees and volunteers, all boards, commissions and/or authorities and board members, including employees and volunteers thereof.
8. **Cancellation Notice:** Workers' Compensation Insurance, General Liability Insurance, Motor Vehicle Liability Insurance, and Professional Liability Insurance, as described above, shall include an endorsement stating the following: "It is understood and agreed that Thirty (30) Days Advance Written Notice of Cancellation, Non-Renewal, Reduction and/or Material Change shall be sent to: CITY OF MUSKEGON ENGINEERING DEPARTMENT.
9. **Proof of Insurance Coverage:** The BIDDER shall provide the CITY at the time the contracts are returned by him for execution, certificates and policies as listed below:
 - a. Two (2) copies of Certificate of Insurance for Workers' Compensation Insurance.
 - b. Two (2) copies of Certificate of Insurance for Commercial General Liability Insurance.
 - c. Two (2) copies of Certificate of Insurance for Vehicle Liability Insurance.
 - d. Two (2) copies of Certificate of Insurance for Professional Liability Insurance.
 - e. If so requested, certified copies of all policies mentioned above will be furnished.
10. If any of the above coverage expires during the term of this contract, the BIDDER shall deliver renewal certificates and/or policies to the CITY at least ten (10) days prior to the expiration date.